



# Hot Water Systems

## Features

JHC Burner Control Centers are specifically designed for the control of burners used in seed dryers. They incorporate state of the art flame control components and are designed to provide the operator with both control and process feedback. Some of these features include:

- Honeywell Rm7890 Flame Control
- Enhanced User Interface
- UL and NFPA Compliance

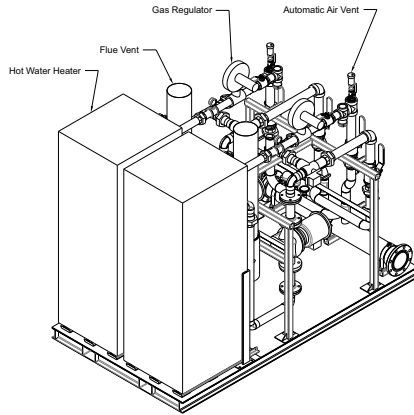

## Customization

The has standard features such as specialized sensors and BCC controls that provide tighter control of the heated air produced for the seed drying process. also offers complete customization JHC to meet your seed drying needs.

Customizable features include:

- Flame Safety Sensors
- Temp. Controllers
- Variable Fan Speed Controls

## Specifications

- Operating Power: 110 VAC @ 10VA
- Gas Safety Controller: Honeywell RM7890
- Flame Sensor Type: Flame Rod Std. - Other types avail.
- PLCML TM Micrologix AB Base Design: 1100 w/ memory
- Interior Controls: Basic Fan - Burner Controls inside
- Dimensions: Model 1B - 24(h) x 24(w) x 9(d)
- Weight: Model 1B - 90 lbs. Model 2A & 2B - 110 lbs.
- Enclosure Rating: NEMA 4/12



**JHC** specializes in seed dryer management systems, controls and renovation. We offer a comprehensive range of dryer products and services and can assist you with all your dryer maintenance and upgrade needs. JHC has provided innovative products and services to the seed production and research industries for over 30 years.

Visit our website, or call our office at (515) 465-3567 for additional information regarding other products and services available from the **Jacobsen Holz Corporation** ([www.jacobsenholz.com](http://www.jacobsenholz.com)).

SM140-1214-02

